

Design Driven Acoustics

GEO TILE

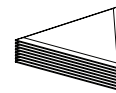

GEO TILES

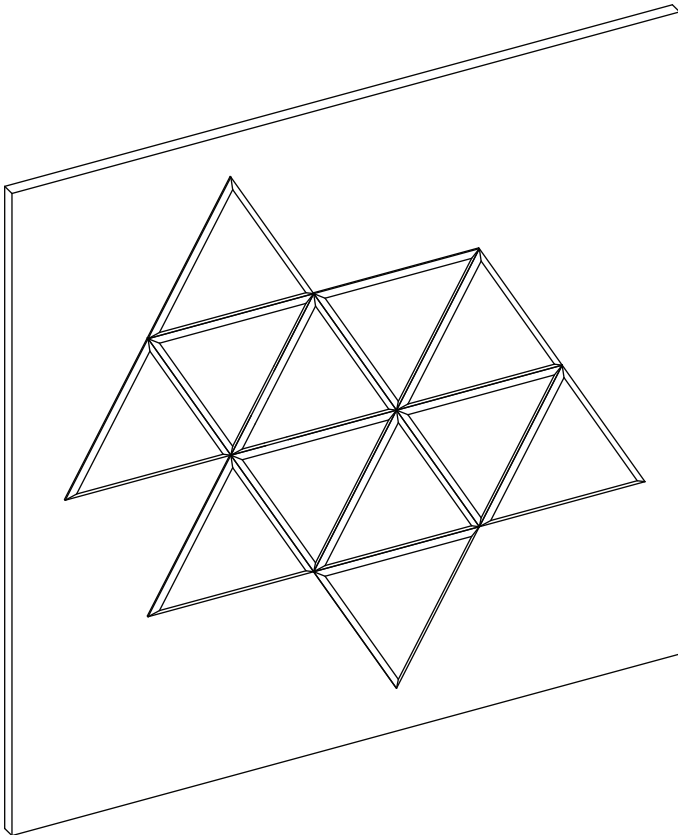
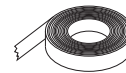

EZO TAPE

*Images reflect typical hardware options. Please refer to packing list for items & quantities specific to your order.

Thank you for your order!

For questions or concerns regarding your order or installation please contact customer service at 1-844-441-1122 or via email at sales@ayrsonics.com (Canada) or info@usa.ayrsonics.com (USA)

www.ezobord.com

GEO TILE EZO TAPE

1 Apply EzoTape to outer edges of reverse side of tiles approximately 1/8" inset from edge
*If tiles exceed 24" apply EzoTape in vertical direction every 12-16" (16" for 9mm material, 12" for 12 mm material)

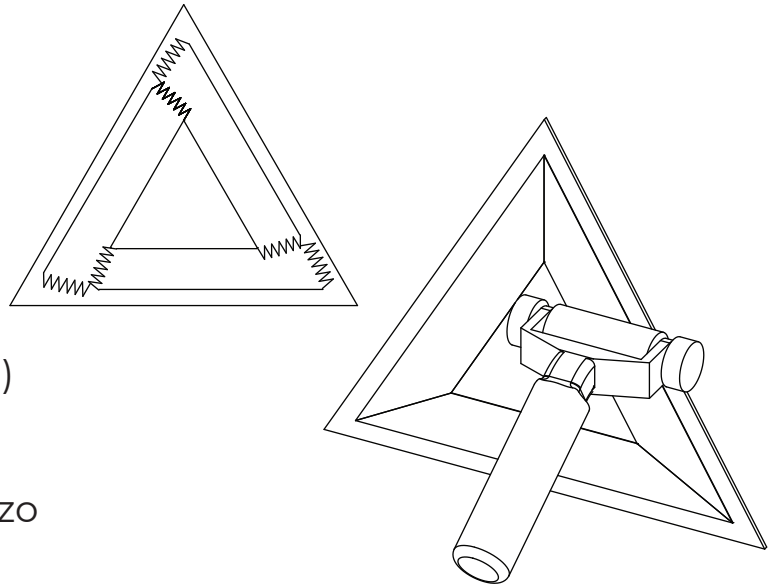

2 Use roller to burnish tape to ensure proper adhesion to Ezo

3 Map locations of tiles on wall using template if required

4 Remove tape backing and apply tiles

5 Firmly burnish Ezo with roller to ensure proper adhesion to wall

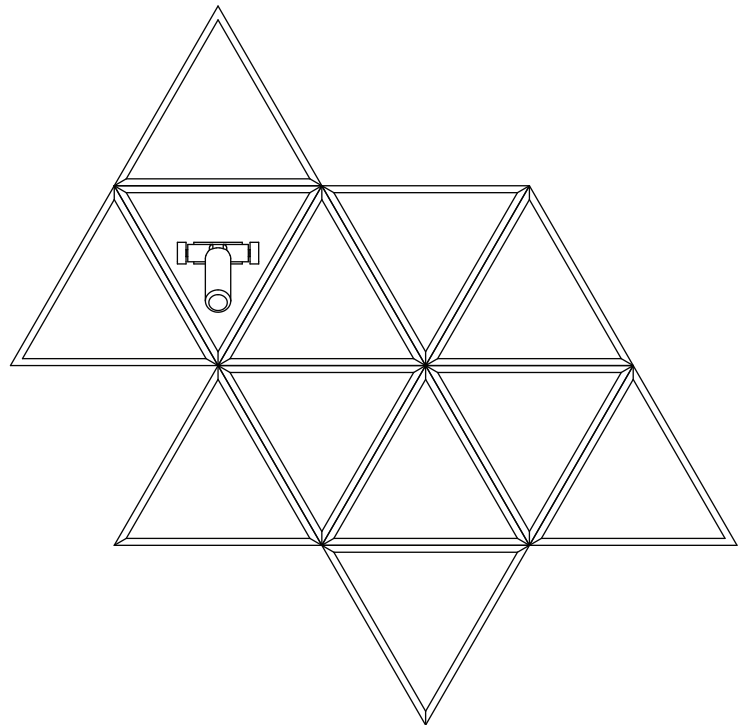

Recommended Tools

Roller
Level
Laser
Knife

ezoBord™

Design Driven Acoustics